

REV	ECA NO.	DESCRIPTION

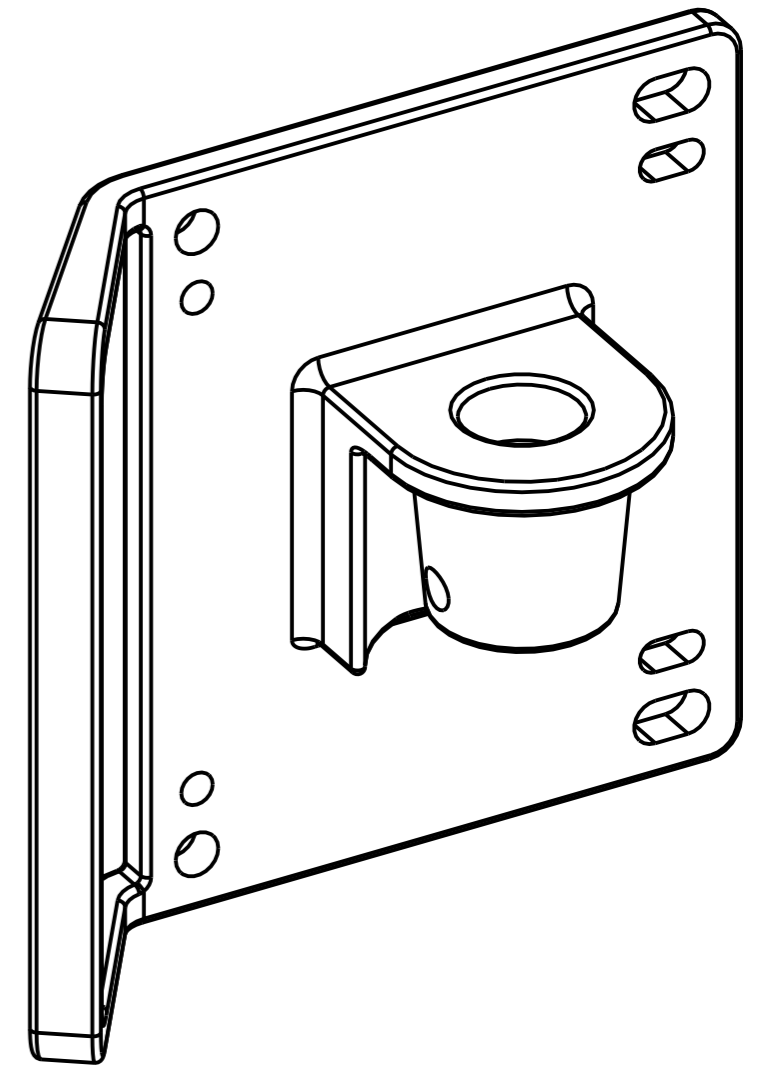
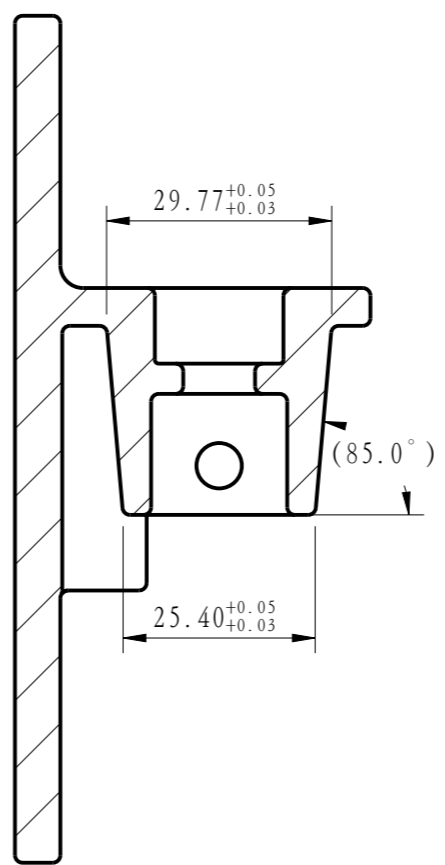
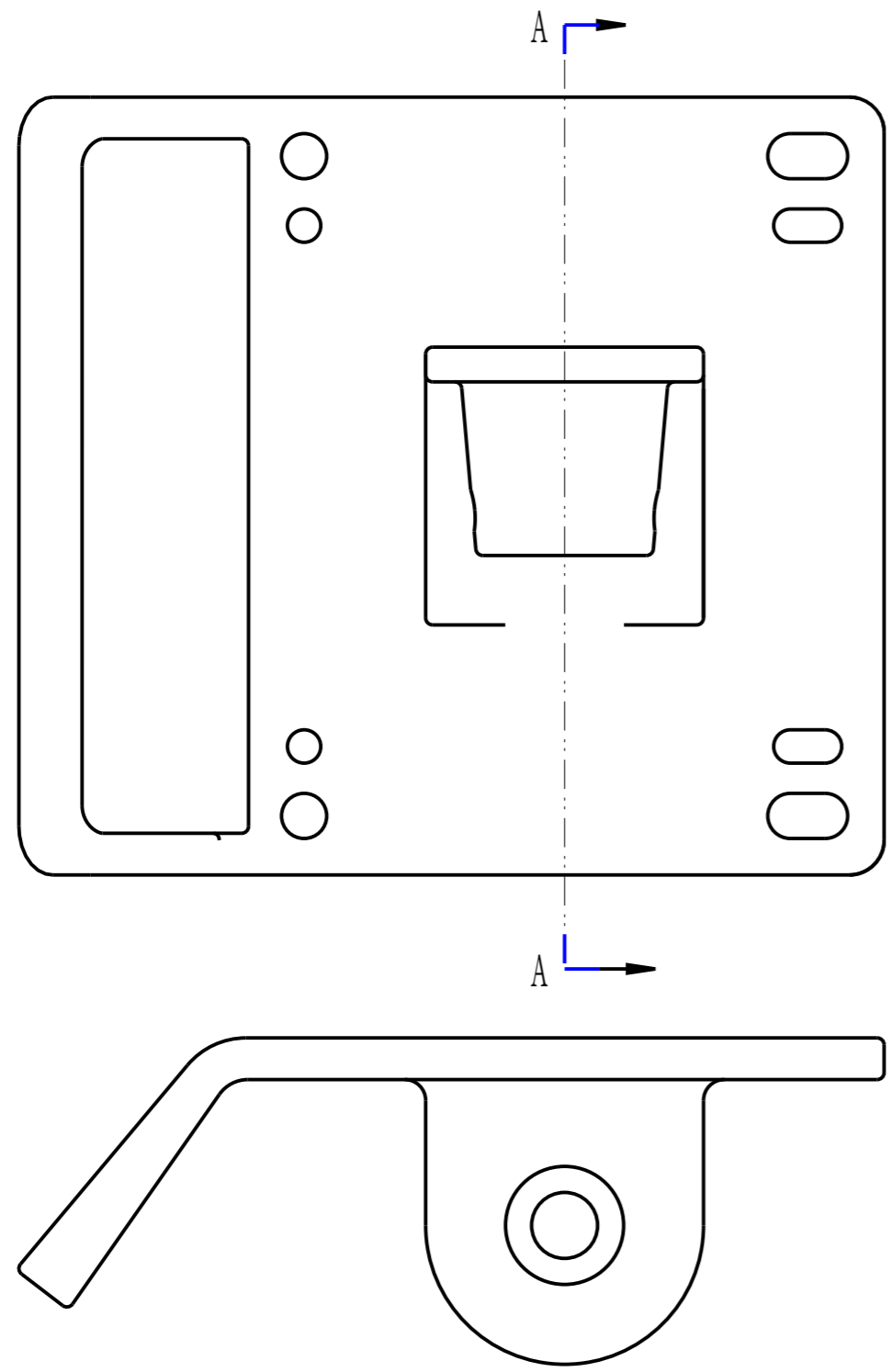

- NOTE:
- All round radius are R0.5~R0.7 except especial declaration.
除特殊说明外,所有圆角半径在R0.5~R0.7
 - All the draft angle is 0.5° except especial declaration.
除特殊说明外,所有的拔模斜度均为0.5
 - All the wall-thickness is 2 mm except especial declaration.
除特殊说明外,所有的壁厚均为2
 - The art design on the surface of casting should be accorded with film.
铸件表面的图案设计应与薄膜一致
 - Sandblasting (polishing etc.) should be used on the surface.
表面喷砂(或研磨等)
 - Processing remains should be reserved on the machine-processing surface.
机加表面在压铸过程中被保留
 - The undefined dimensions refer to the PRO/E 3D model.
未注尺寸参照PRO/E 3D模型

	HUAWEI TECHNOLOGIES Co.,LTD		TITLE: mount accessories		
	DRAW: laiyang	DATE: &PDRAWN_DATE	UNIT'S: MM	DWG NO.: DKBA8.019.5770	DWG VER: B
	CHKD: liuzhongxin	DATE: 31-May-14	FINISH: L015_3	ITEM NO.:	ITEM REV:
	YRFD: /	DATE: /	MASS(Kg): 0.242		
	APPD: /	DATE: /	SCALE: 1:1	SHEET: 1 OF 1 MAT'L: A1,6061-T6	
THESE DRAWINGS AND SPECIFICATION ARE THE PROPERTY OF HUAWEI TECH Co.,LTD. AND SHOULD NOT BE REPRODUCED COPIED OR USED IN ANY MANNER WITHOUT THE PRIOR WRITTEN CONSENT OF HUAWEI TECH Co.,LTD.			PRODUCT:		

RELEASE LEVEL: [] Prototype
FILE NAME: DKBA80195770